

**ENTRY-LEVEL ASSESSMENT
THROUGH FALL 2011**
December 2012

ROGERS STATE UNIVERSITY
Claremore, Oklahoma

Office of Accountability and Academics



Entry-Level Assessment Through Fall 2011

Prepared by

Accountability and Academics

Dr. Mary Millikin, Assistant Vice President

Michelle Canan, Research Analyst

Entry-level Assessment

The purpose of entry-level assessment at Rogers State University (RSU) is to analyze the college preparedness of all new students – first-time freshmen as well as transfer students. All students admitted to Rogers State University are required to participate in a variety of assessment activities. RSU provides a program of basic skills testing and several developmental courses that are designed to help students enhance their proficiency in the basic skill areas of English, mathematics, reading, and science. Students required to enroll in these courses will ultimately benefit by having stronger skills in these important academic abilities.

Curricular Proficiency Model

Developmental coursework may be required when a first-time freshman has the following subscores on the ACT:

ACT in English below 19

ACT in math below 19

ACT in reading below 19

ACT in science below 19

Students who do not meet the cutscore of 19 on each ACT subtest are referred for secondary testing. The ACT COMPASS is the secondary test for English, reading and mathematics, and the Stanford Test of Academic Skills – Science (STASS) is the secondary test for science. With the exception of the STASS test, students who do not pass secondary testing on the first attempt may retake the test one time after a one-week waiting period. Developmental courses must be completed within the first 24 semester hours attempted for first-time freshmen (12 semester hours for transfer students); otherwise, future enrollments by the student will be limited to only the required zero-level courses until successful completion. A grade of “C” or higher is required to clear a developmental course requirement. *Table 1: Curricular Proficiency Model* provides a visual representation of the entry-level assessment plan at Rogers State University.

During fall 2011, all entering students were evaluated on the basis of ACT scores, secondary testing, or prior coursework. During that period, 855 academically deficient students accounted for 1182 enrollments in courses, as follows: Basic Writing (275), Reading I (120), Science Proficiency (46), and Algebra (741).¹

Student Success Rates in College-Level Coursework

RSU tracks performance in college-level coursework of students who have completed developmental courses. Success rates in math, English, reading and science are presented in Tables 2, 3, 4 and 5 respectively. To clarify, *Table 2: Success Rates of Math Deficient Students* provides tracking data demonstrating successful or unsuccessful academic performance by student headcount in MATH 0114 Elementary Algebra and MATH 0213 Intermediate Algebra. Student achievement is tracked over a three year period in order to examine the performance of those placed in MATH 0114, a prerequisite to MATH 0213, which is a prerequisite to MATH 1513 College Algebra or MATH

¹ Rogers State University. (2011). *Enrollment Report Fall Semester 2011*.

<http://www.rsu.edu/accountability/docs/reports-surveys/EnrollmentReportFall11.pdf>

1503 Mathematics for Critical Thinking. By comparison, a description is provided of the academic performance of students placed directly into MATH 1513 or MATH 1503 based on the ACT, COMPASS and other method (transfer course, etc.).

The vertical numbers in each box of the flowchart represent percentages of successful and unsuccessful student performance. The three columns represent the fall semesters of 2009, 2010 and 2011. The headcount (number) of students is found in the parentheses at the bottom of the column. Successful performance is defined as course grades of A, B or C. Unsuccessful performance is defined as D, F, I or W. Withdrawal percentages are extracted from the whole.

Table 6: Success Rates in Detail amplify the previous tables to provide information about student cohorts who enrolled in the specified courses for the fall semesters of 2007-2011. For example, 392 students enrolled in MATH 0114 during the fall 2011 semester. Of the 392 students, 169 (43%) earned the grade of A, B or C, which are considered "successful". Unsuccessful performance, as defined as D, F, W or I, was earned by 223 (57%). Of the successful cohort of 169 students, 129 enrolled in MATH 0213 for the spring 2012 semester. Seventy percent (70%) out of 129 students were successful. Of the 90 students remaining in the successful cohort group, 59 students enrolled MATH 1513 College Algebra during the summer 2012 or fall 2012 semester. In summary, 34 students out of the original cohort of 392 successfully completed MATH 1513. This tracking model does not include students who "stopped out" of the curricular area, e.g., math.

Executive Summary

The Entry-Level Assessment Report tracks performance in college-level coursework of students who have completed developmental courses. The tables found in the report present success rates in math, English, reading and science. In most instances, the success rates remained steady, some slightly higher, some slightly lower, than the previous year.

It appears, from the data collected, that students who start with MATH 0213 Intermediate Algebra have a slightly higher percentage of success in the college-level math course than their counterparts who started with MATH 0114 Elementary Algebra Plus. There was an increase in the successful percentage for students in MATH 1513 College Algebra whose Compass score exempted them from the remedial math coursework. The base number was low at only 11 students; however, 73% successfully completed College Algebra.

The rate of successful completers of ENGL 0003 Basic Writing had a significant decrease from 57% for fall 2009 to 37% for fall 2010 to 29% for fall 2011. Of the 274 students who enrolled in ENGL 0003 for fall 2011, only 79 students passed the course with an A, B, or C. One hundred fifty-two (152) students received a grade of D or F in the course. There was a slight decline for those 79 successful ENGL 0003 Basic Writing completers shown in the success rates of ENGL 1113 Composition I. The fall 2011 success rate of 72% was a decrease of 5% over fall 2010. There was one significant increase in the successful percentage in the English area. For fall 2011, 73% of the students whose Compass scores cleared their remedial successfully passed ENGL 1213 Composition II as opposed to 62% for fall 2010.

There were some demonstrations of decreases in success rates for READ 0223 and BIOL 0123. The base numbers for some of these areas were low, making it difficult to determine the significance of the changes in percentage.

In summary, most of the success rates remained consistent with the previous years. However, there is a cause for concern regarding the success rates of ENGL 0003 Basic Writing and READ 0223 Developmental Reading I students.

Table 1: Curricular Proficiency Model

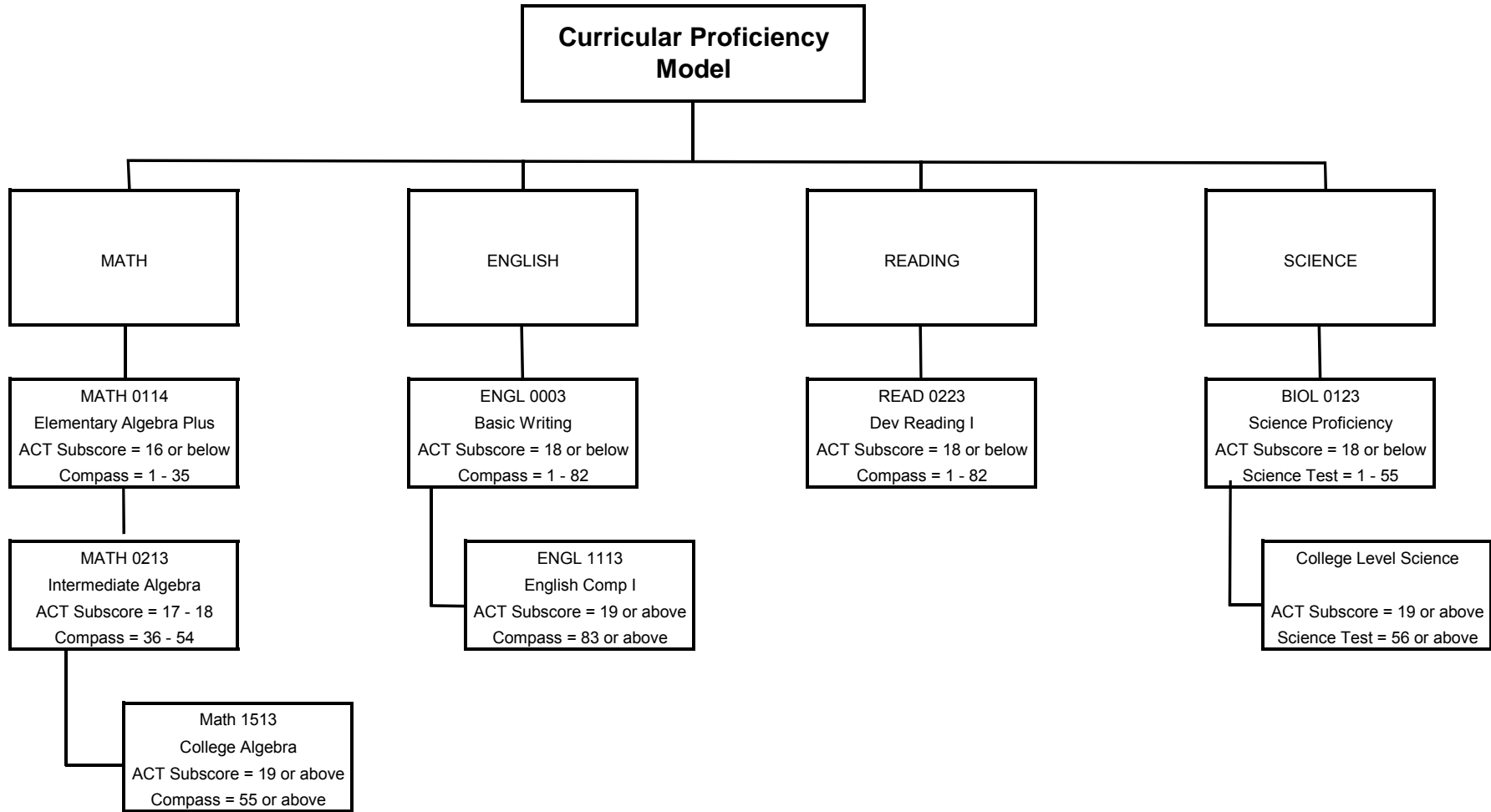

- Proficiency established within 24 credit hours or 12 credit hours if transfer.
- Intermediate Algebra is prerequisite for Math 1503, Math 1513, or PHYS 1014.

Table 2: Success Rates of Math Deficient Students

MATH
Fall 09-Fal 10-Fall 11 Percentage
(headcount)

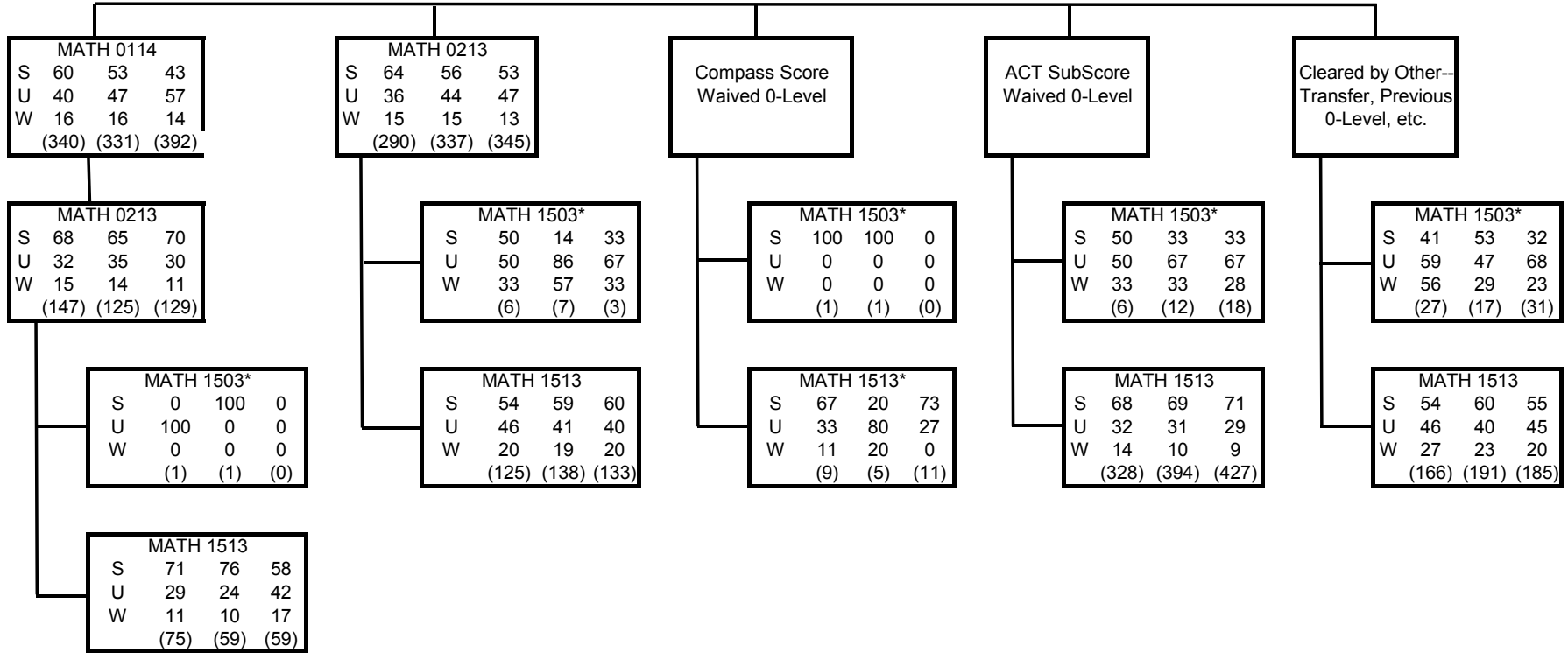

* Low Bases
S = Successful (A, B, or C)
U = Unsuccessful (D, F, I, or W)
W = Withdrawal

Table 3: Success Rates of English Deficient Students

ENGLISH
Fall 09-Fal 10-Fall 11 Percentage
(headcount)

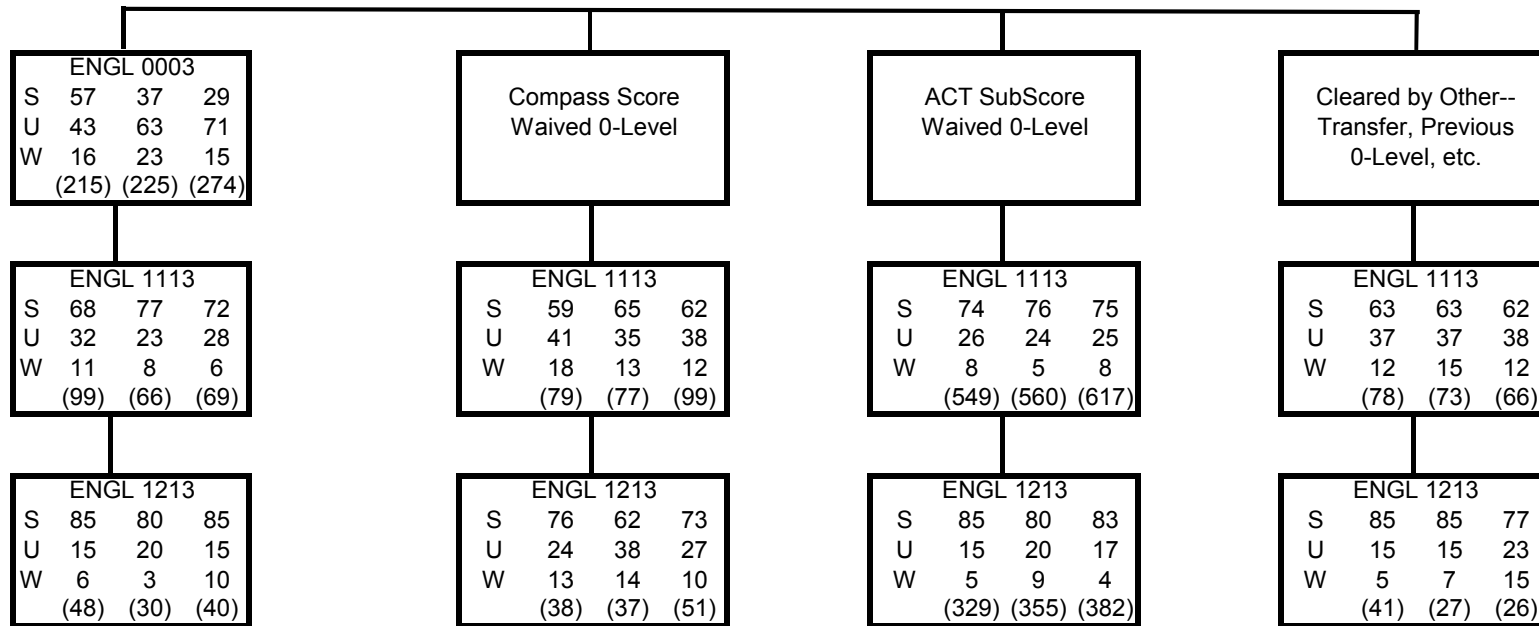

S = Successful (A, B, or C)
 U = Unsuccessful (D, F, I, or W)
 W = Withdrawal

Table 4: Success Rates of Reading Deficient Students

READING

Fall 09-Fal 10-Fall 11 Percentage
(headcount)

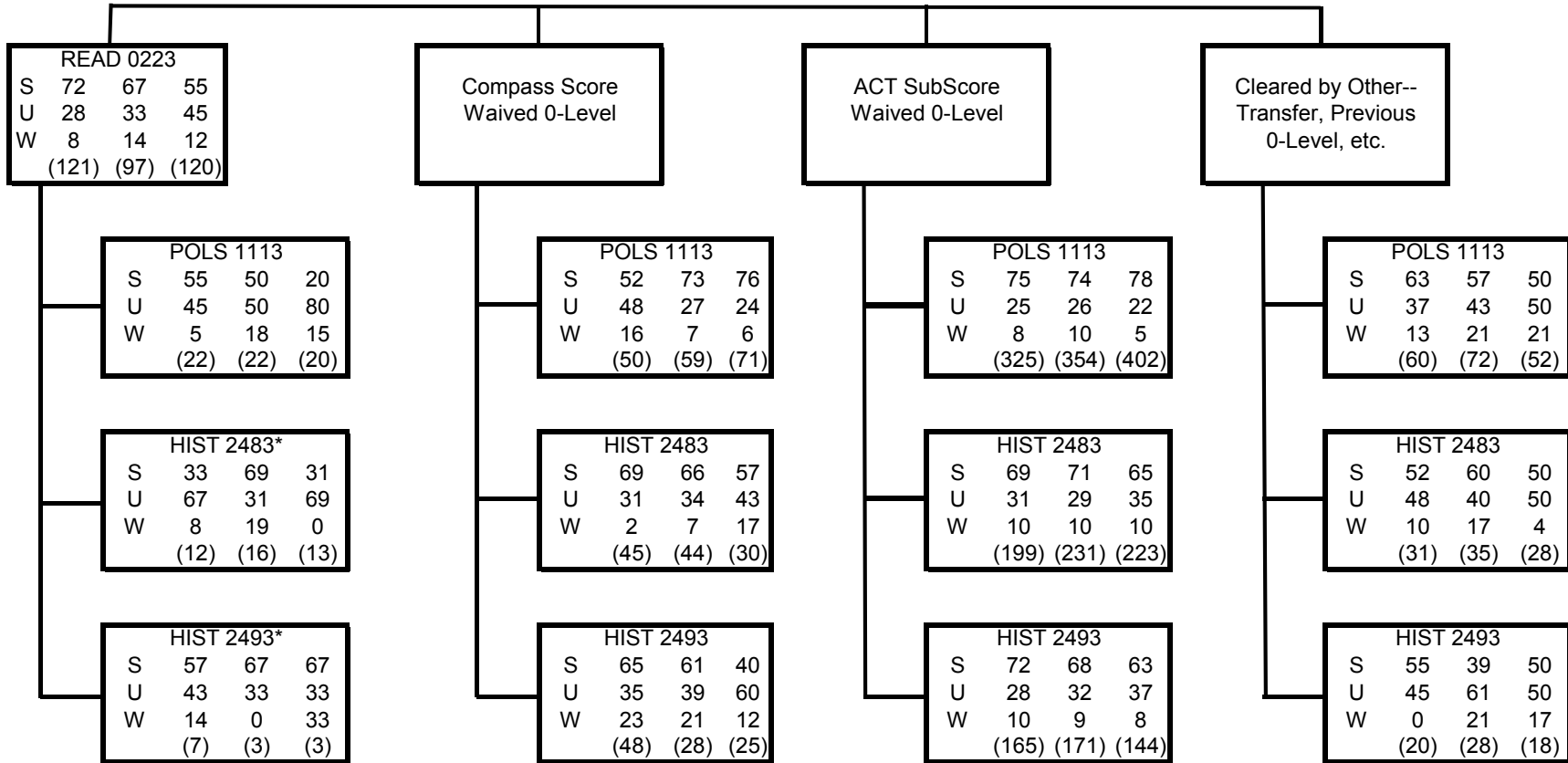

* Low Bases

S = Successful (A, B, or C)

U = Unsuccessful (D, F, I, or W)

W = Withdrawal

Table 5: Success Rates of Science Deficient Students

SCIENCE

Fall 09-Fal 10-Fall 11 Percentage
(headcount)

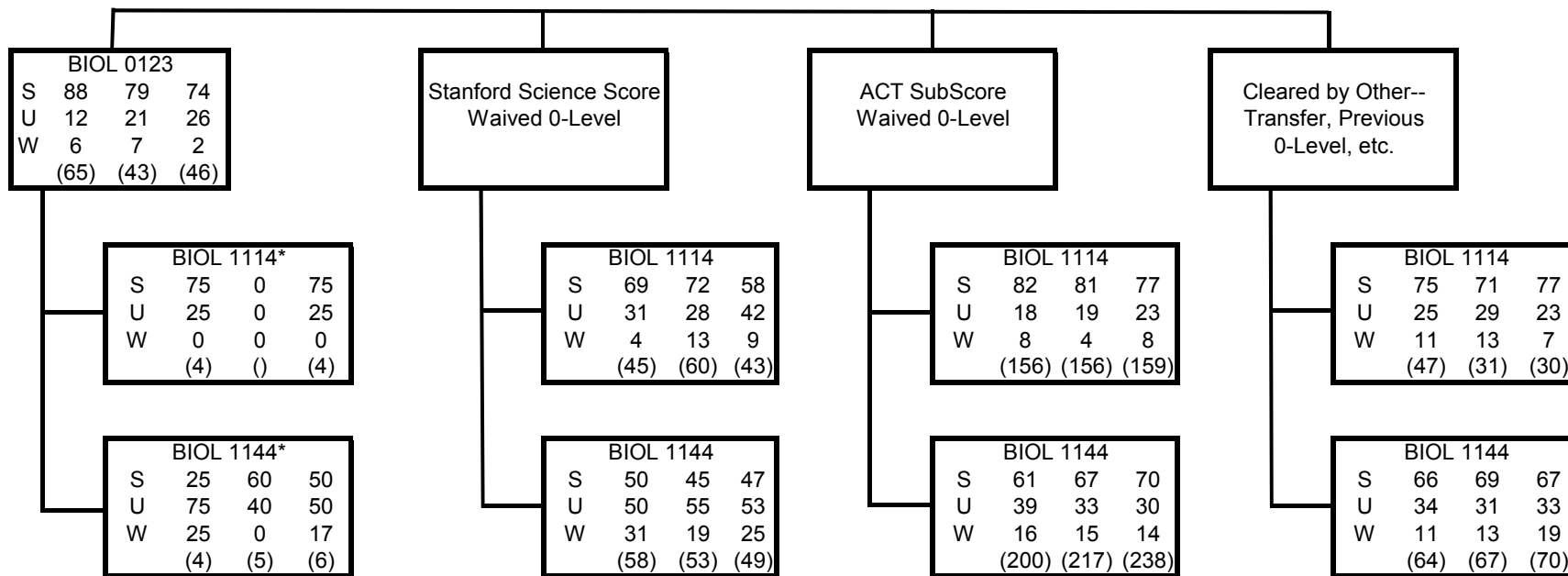

* Low Bases

S = Successful (A, B, or C)

U = Unsuccessful (D, F, I, or W)

W = Withdrawal

Table 6: Success Rates in Detail

	Fall 2007		Fall 2008		Fall 2009		Fall 2010		Fall 2011	
	actual	percentage	actual	percentage	actual	percentage	actual	percentage	actual	percentage
Math										
Total Enrolled in Math 0114	323	100.00%	291	100.00%	340	100.00%	331	100.00%	392	100.00%
A, B, or C	156	48.30%	153	52.58%	204	60.00%	176	53.17%	169	43.11%
D or F	101	31.27%	88	30.24%	81	23.82%	103	31.12%	169	43.11%
I	2	0.62%	0	0.00%	0	0.00%	0	0.00%	0	0.00%
W	64	19.81%	50	17.18%	55	16.18%	52	15.71%	54	13.78%
Continued Immediately with Math 0213 (completed Math 0114 with A, B, or C)	106	100.00%	103	100.00%	147	100.00%	125	100.00%	129	100.00%
A, B, or C	76	71.70%	65	63.11%	100	68.03%	81	64.80%	90	69.77%
D or F	13	12.26%	28	27.18%	25	17.01%	27	21.60%	25	19.38%
I	0	0.00%	0	0.00%	0	0.00%	0	0.00%	0	0.00%
W	17	16.04%	10	9.71%	22	14.97%	17	13.60%	14	10.85%
Continued Immediately with: (completed Math 0213 with A, B, or C)										
Math 1503	0	0.00%	1	100.00%	1	100.00%	1	100.00%	0	0.00%
A, B, or C	0	0.00%	1	100.00%	0	0.00%	1	100.00%	0	0.00%
D or F	0	0.00%	0	0.00%	0	0.00%	0	0.00%	0	0.00%
I	0	0.00%	0	0.00%	1	100.00%	0	0.00%	0	0.00%
W	0	0.00%	0	0.00%	0	0.00%	0	0.00%	0	0.00%
Math 1513	46	100.00%	42	100.00%	75	100.00%	59	100.00%	59	100.00%
A, B, or C	32	69.57%	28	66.67%	53	70.67%	45	76.27%	34	57.63%
D or F	7	15.22%	4	9.52%	14	18.67%	8	13.56%	15	25.42%
I	0	0.00%	0	0.00%	0	0.00%	0	0.00%	0	0.00%
W	7	15.22%	10	23.81%	8	10.67%	6	10.17%	10	16.95%

	Fall 2007		Fall 2008		Fall 2009		Fall 2010		Fall 2011	
	actual	percentage	actual	percentage	actual	percentage	actual	percentage	actual	percentage
Total Enrolled in Math 0213 (tested out of Math 0114)	286	100.00%	278	100.00%	290	100.00%	337	100.00%	345	100.00%
A, B, or C	167	58.39%	169	60.79%	185	63.79%	188	55.79%	184	53.33%
D or F	67	23.43%	64	23.02%	62	21.38%	98	29.08%	117	33.91%
I	0	0.00%	0	0.00%	0	0.00%	0	0.00%	0	0.00%
W	52	18.18%	45	16.19%	43	14.83%	51	15.13%	44	12.75%
Continued Immediately with: (completed Math 0213 with A, B, or C)										
Math 1503	0	0.00%	3	100.00%	6	100.00%	7	100.00%	3	100.00%
A, B, or C	0	0.00%	1	33.33%	3	50.00%	1	14.29%	1	33.33%
D or F	0	0.00%	0	0.00%	1	16.67%	2	28.57%	1	33.33%
I	0	0.00%	0	0.00%	0	0.00%	0	0.00%	0	0.00%
W	0	0.00%	2	66.67%	2	33.33%	4	57.14%	1	33.33%
Math 1513	108	100.00%	119	100.00%	125	100.00%	138	100.00%	133	100.00%
A, B, or C	63	58.33%	73	61.34%	67	53.60%	82	59.42%	80	60.15%
D or F	26	24.07%	29	24.37%	33	26.40%	30	21.74%	26	19.55%
I	0	0.00%	0	0.00%	0	0.00%	0	0.00%	0	0.00%
W	19	17.59%	17	14.29%	25	20.00%	26	18.84%	27	20.30%

Enrolled in: (Scored high enough on Compass to waive zero-level)										
Math 1503	1	100.00%	0	0.00%	1	100.00%	1	100.00%	0	0.00%
A, B, or C	1	100.00%	0	0.00%	1	100.00%	1	100.00%	0	0.00%
D or F	0	0.00%	0	0.00%	0	0.00%	0	0.00%	0	0.00%
I	0	0.00%	0	0.00%	0	0.00%	0	0.00%	0	0.00%
W	0	0.00%	0	0.00%	0	0.00%	0	0.00%	0	0.00%
Math 1513	21	100.00%	8	100.00%	9	100.00%	5	100.00%	11	100.00%
A, B, or C	9	42.86%	5	62.50%	6	66.67%	1	20.00%	8	72.73%
D or F	9	42.86%	1	12.50%	2	22.22%	3	60.00%	3	27.27%
I	0	0.00%	0	0.00%	0	0.00%	0	0.00%	0	0.00%
W	3	14.29%	2	25.00%	1	11.11%	1	20.00%	0	0.00%

	Fall 2007		Fall 2008		Fall 2009		Fall 2010		Fall 2011	
	actual	percentage	actual	percentage	actual	percentage	actual	percentage	actual	percentage
Enrolled in: (Scored high enough on ACT to waive zero-level)										
Math 1503	14	100.00%	15	100.00%	6	100.00%	12	100.00%	18	100.00%
A, B, or C	4	28.57%	10	66.67%	3	50.00%	4	33.33%	6	33.33%
D or F	4	28.57%	4	26.67%	1	16.67%	3	25.00%	7	38.89%
I	0	0.00%	0	0.00%	0	0.00%	0	0.00%	0	0.00%
W	6	42.86%	1	6.67%	2	33.33%	4	33.33%	5	27.78%
N	0	0.00%	0	0.00%	0	0.00%	1	8.33%	0	0.00%
Math 1513	313	100.00%	312	100.00%	328	100.00%	394	100.00%	427	100.00%
A, B, or C	192	61.34%	219	70.19%	223	67.99%	271	68.78%	304	71.19%
D or F	75	23.96%	56	17.95%	58	17.68%	81	20.56%	84	19.67%
I	0	0.00%	0	0.00%	0	0.00%	0	0.00%	0	0.00%
W	46	14.70%	37	11.86%	47	14.33%	41	10.41%	37	8.67%
N	0	0.00%	0	0.00%	0	0.00%	1	0.25%	2	0.47%

Enrolled in: (Remedial cleared by other ways--transfer, previous zero-level,etc.)										
Math 1503	24	100.00%	26	100.00%	27	100.00%	17	100.00%	31	100.00%
A, B, or C	5	20.83%	5	19.23%	11	40.74%	9	52.94%	10	32.26%
D or F	9	37.50%	6	23.08%	1	3.70%	3	17.65%	14	45.16%
I	0	0.00%	0	0.00%	0	0.00%	0	0.00%	0	0.00%
W	10	41.67%	15	57.69%	15	55.56%	5	29.41%	7	22.58%
Math 1513	159	100.00%	153	100.00%	166	100.00%	191	100.00%	185	100.00%
A, B, or C	78	49.06%	85	55.56%	90	54.22%	115	60.21%	101	54.59%
D or F	33	20.75%	40	26.14%	31	18.67%	33	17.28%	47	25.41%
I	0	0.00%	0	0.00%	0	0.00%	0	0.00%	0	0.00%
W	48	30.19%	28	18.30%	45	27.11%	43	22.51%	37	20.00%
AU	0	0.00%	0	0.00%	0	0.00%	0	0.00%	0	0.00%

English

	Fall 2007		Fall 2008		Fall 2009		Fall 2010		Fall 2011	
	actual	percentage	actual	percentage	actual	percentage	actual	percentage	actual	percentage
Total Enrolled in Engl 0003	242	100.00%	226	100.00%	215	100.00%	225	100.00%	274	100.00%
A, B, or C	137	56.61%	132	58.41%	122	56.74%	83	36.89%	79	28.83%
D or F	76	31.40%	71	31.42%	59	27.44%	91	40.44%	152	55.47%
I	0	0.00%	1	0.44%	0	0.00%	0	0.00%	0	0.00%
W	28	11.57%	22	9.73%	34	15.81%	51	22.67%	42	15.33%
N	1	0.41%	0	0.00%	0	0.00%	0	0.00%	0	0.00%
AU	0	0.00%	0	0.00%	0	0.00%	0	0.00%	1	0.36%
Continued Immediately with Engl 1113 (completed Engl 0003 with A, B, or C)	109	100.00%	98	100.00%	99	100.00%	66	100.00%	69	100.00%
A, B, or C	69	63.30%	60	61.22%	67	67.68%	51	77.27%	50	72.46%
D or F	27	24.77%	23	23.47%	21	21.21%	10	15.15%	17	24.64%
I	0	0.00%	0	0.00%	0	0.00%	0	0.00%	0	0.00%
W	13	11.93%	15	15.31%	11	11.11%	5	7.58%	2	2.90%
Continued Immediately with Engl 1213 (completed Engl 1113 with A, B, C, or D)	50	100.00%	42	100.00%	48	100.00%	30	100.00%	40	100.00%
A, B, or C	37	74.00%	33	78.57%	41	85.42%	24	80.00%	34	85.00%
D or F	7	14.00%	4	9.52%	4	8.33%	5	16.67%	2	5.00%
I	0	0.00%	1	2.38%	0	0.00%	0	0.00%	0	0.00%
W	6	12.00%	4	9.52%	3	6.25%	1	3.33%	4	10.00%

Enrolled in Engl 1113: (Scored high enough on Compass to waive zero-level)	74	100.00%	61	100.00%	79	100.00%	77	100.00%	99	100.00%
A, B, or C	51	68.92%	39	63.93%	47	59.49%	50	64.94%	61	61.62%
D or F	16	21.62%	14	22.95%	18	22.78%	17	22.08%	26	26.26%
I	0	0.00%	0	0.00%	0	0.00%	0	0.00%	0	0.00%
W	7	9.46%	8	13.11%	14	17.72%	10	12.99%	12	12.12%
Continued Immediately with Engl 1213: (completed Engl 1113 with A, B, C, or D)	36	100.00%	30	100.00%	38	100.00%	37	100.00%	51	100.00%
A, B, or C	25	69.44%	28	93.33%	29	76.32%	23	62.16%	37	72.55%
D or F	6	16.67%	2	6.67%	4	10.53%	9	24.32%	9	17.65%
I	0	0.00%	0	0.00%	0	0.00%	0	0.00%	0	0.00%
W	5	13.89%	0	0.00%	5	13.16%	5	13.51%	5	9.80%

	Fall 2007		Fall 2008		Fall 2009		Fall 2010		Fall 2011	
	actual	percentage	actual	percentage	actual	percentage	actual	percentage	actual	percentage
Enrolled in Engl 1113: (Scored high enough on ACT to waive zero-level)	451	100.00%	461	100.00%	549	100.00%	560	100.00%	617	100.00%
A, B, or C	300	66.52%	344	74.62%	408	74.32%	424	75.71%	460	74.55%
D or F	96	21.29%	87	18.87%	97	17.67%	108	19.29%	107	17.34%
I	0	0.00%	0	0.00%	0	0.00%	0	0.00%	0	0.00%
W	55	12.20%	30	6.51%	44	8.01%	28	5.00%	50	8.10%
Continued Immediately with Engl 1213: (completed Engl 1113 with A, B, C, or D)	225	100.00%	276	100.00%	329	100.00%	355	100.00%	382	100.00%
A, B, or C	184	81.78%	229	82.97%	280	85.11%	284	80.00%	318	83.25%
D or F	25	11.11%	28	10.14%	31	9.42%	40	11.27%	48	12.57%
I	0	0.00%	1	0.36%	0	0.00%	0	0.00%	0	0.00%
W	16	7.11%	18	6.52%	18	5.47%	31	8.73%	16	4.19%

Enrolled in Engl 1113: (Remedial cleared other ways-transfer, previous zero-level,etc.)	81	100.00%	58	100.00%	78	100.00%	73	100.00%	66	100.00%
A, B, or C	61	75.31%	37	63.79%	49	62.82%	46	63.01%	41	62.12%
D or F	13	16.05%	16	27.59%	20	25.64%	16	21.92%	17	25.76%
I	1	1.23%	0	0.00%	0	0.00%	0	0.00%	0	0.00%
W	6	7.41%	5	8.62%	9	11.54%	11	15.07%	8	12.12%
Continued Immediately with Engl 1213: (completed Engl 1113 with A, B, C, or D)	33	100.00%	26	100.00%	41	100.00%	27	100.00%	26	100.00%
A, B, or C	30	90.91%	19	73.08%	35	85.37%	23	85.19%	20	76.92%
D or F	1	3.03%	5	19.23%	4	9.76%	2	7.41%	2	7.69%
I	0	0.00%	0	0.00%	0	0.00%	0	0.00%	0	0.00%
W	2	6.06%	2	7.69%	2	4.88%	2	7.41%	4	15.38%

Reading

	Fall 2007		Fall 2008		Fall 2009		Fall 2010		Fall 2011	
	actual	percentage	actual	percentage	actual	percentage	actual	percentage	actual	percentage
Total Enrolled in Read 0223	121	100.00%	115	100.00%	121	100.00%	97	100.00%	120	100.00%
A, B, or C	69	57.02%	73	63.48%	87	71.90%	65	67.01%	66	55.00%
D or F	34	28.10%	30	26.09%	24	19.83%	18	18.56%	40	33.33%
I	0	0.00%	0	0.00%	0	0.00%	0	0.00%	0	0.00%
W	18	14.88%	12	10.43%	10	8.26%	14	14.43%	14	11.67%
Continued Immediately with: (completed Read 0223 with A, B, or C)										
Pols 1113	21	100.00%	20	100.00%	22	100.00%	22	100.00%	20	100.00%
A, B, or C	13	61.90%	7	35.00%	12	54.55%	11	50.00%	4	20.00%
D or F	5	23.81%	12	60.00%	9	40.91%	7	31.82%	13	65.00%
I	1	4.76%	0	0.00%	0	0.00%	0	0.00%	0	0.00%
W	2	9.52%	1	5.00%	1	4.55%	4	18.18%	3	15.00%
Hist 2483	9	100.00%	13	100.00%	12	100.00%	16	100.00%	13	100.00%
A, B, or C	3	33.33%	5	38.46%	4	33.33%	11	68.75%	4	30.77%
D or F	4	44.44%	8	61.54%	7	58.33%	2	12.50%	9	69.23%
I	0	0.00%	0	0.00%	0	0.00%	0	0.00%	0	0.00%
W	2	22.22%	0	0.00%	1	8.33%	3	18.75%	0	0.00%
Hist 2493	7	100.00%	15	100.00%	7	100.00%	3	100.00%	3	100.00%
A, B, or C	4	57.14%	6	40.00%	4	57.14%	2	66.67%	2	66.67%
D or F	2	28.57%	6	40.00%	2	28.57%	1	33.33%	0	0.00%
I	1	14.29%	0	0.00%	0	0.00%	0	0.00%	0	0.00%
W	0	0.00%	3	20.00%	1	14.29%	0	0.00%	1	33.33%

Enrolled in: (Scored high enough on Compass to waive zero-level)										
Pols 1113	62	100.00%	58	100.00%	50	100.00%	59	100.00%	71	100.00%
A, B, or C	39	62.90%	44	75.86%	26	52.00%	43	72.88%	54	76.06%
D or F	14	22.58%	7	12.07%	16	32.00%	12	20.34%	13	18.31%
I	0	0.00%	0	0.00%	0	0.00%	0	0.00%	0	0.00%
W	9	14.52%	7	12.07%	8	16.00%	4	6.78%	4	5.63%
Hist 2483	42	100.00%	38	100.00%	45	100.00%	44	100.00%	30	100.00%
A, B, or C	28	66.67%	25	65.79%	31	68.89%	29	65.91%	17	56.67%
D or F	11	26.19%	10	26.32%	13	28.89%	12	27.27%	8	26.67%
I	0	0.00%	1	2.63%	0	0.00%	0	0.00%	0	0.00%
W	3	7.14%	2	5.26%	1	2.22%	3	6.82%	5	16.67%

	Fall 2007		Fall 2008		Fall 2009		Fall 2010		Fall 2011	
	actual	percentage	actual	percentage	actual	percentage	actual	percentage	actual	percentage
Hist 2493	29	100.00%	31	100.00%	48	100.00%	28	100.00%	25	100.00%
A, B, or C	22	75.86%	23	74.19%	31	64.58%	17	60.71%	10	40.00%
D or F	5	17.24%	6	19.35%	6	12.50%	5	17.86%	12	48.00%
I	0	0.00%	0	0.00%	0	0.00%	0	0.00%	0	0.00%
W	2	6.90%	2	6.45%	11	22.92%	6	21.43%	3	12.00%

Enrolled in: (Scored high enough on ACT to waive zero-level)										
Pols 1113	254	100.00%	295	100.00%	325	100.00%	354	100.00%	402	100.00%
A, B, or C	173	68.11%	206	69.83%	244	75.08%	261	73.73%	315	78.36%
D or F	54	21.26%	58	19.66%	56	17.23%	59	16.67%	66	16.42%
I	0	0.00%	0	0.00%	0	0.00%	0	0.00%	0	0.00%
W	27	10.63%	31	10.51%	25	7.69%	34	9.60%	21	5.22%
AU	0	0.00%	0	0.00%	0	0.00%	0	0.00%	0	0.00%
Hist 2483	155	100.00%	165	100.00%	199	100.00%	231	100.00%	223	100.00%
A, B, or C	106	68.39%	115	69.70%	137	68.84%	165	71.43%	146	65.47%
D or F	34	21.94%	44	26.67%	43	21.61%	44	19.05%	55	24.66%
I	0	0.00%	0	0.00%	0	0.00%	0	0.00%	1	0.45%
W	15	9.68%	6	3.64%	19	9.55%	22	9.52%	21	9.42%
Hist 2493	128	100.00%	146	100.00%	165	100.00%	171	100.00%	144	100.00%
A, B, or C	74	57.81%	110	75.34%	118	71.52%	117	68.42%	91	63.19%
D or F	32	25.00%	23	15.75%	31	18.79%	39	22.81%	41	28.47%
I	1	0.78%	1	0.68%	0	0.00%	0	0.00%	0	0.00%
W	21	16.41%	12	8.22%	16	9.70%	15	8.77%	12	8.33%

Enrolled in: (Remedial cleared by other ways-transfer, previous zero-level,etc.)										
Pols 1113	51	100.00%	67	100.00%	60	100.00%	72	100.00%	52	100.00%
A, B, or C	34	66.67%	44	65.67%	38	63.33%	41	56.94%	26	50.00%
D or F	11	21.57%	16	23.88%	14	23.33%	16	22.22%	15	28.85%
I	0	0.00%	0	0.00%	0	0.00%	0	0.00%	0	0.00%
W	6	11.76%	7	10.45%	8	13.33%	15	20.83%	11	21.15%
Hist 2483	37	100.00%	43	100.00%	31	100.00%	35	100.00%	28	100.00%
A, B, or C	23	62.16%	25	58.14%	16	51.61%	21	60.00%	14	50.00%
D or F	9	24.32%	12	27.91%	12	38.71%	8	22.86%	13	46.43%
I	0	0.00%	0	0.00%	0	0.00%	0	0.00%	0	0.00%
W	5	13.51%	6	13.95%	3	9.68%	6	17.14%	1	3.57%

	Fall 2007		Fall 2008		Fall 2009		Fall 2010		Fall 2011	
	actual	percentage	actual	percentage	actual	percentage	actual	percentage	actual	percentage
Hist 2493	32	100.00%	16	100.00%	20	100.00%	28	100.00%	18	100.00%
A, B, or C	16	50.00%	13	81.25%	11	55.00%	11	39.29%	9	50.00%
D or F	10	31.25%	1	6.25%	9	45.00%	11	39.29%	6	33.33%
I	0	0.00%	0	0.00%	0	0.00%	0	0.00%	0	0.00%
W	6	18.75%	2	12.50%	0	0.00%	6	21.43%	3	16.67%

Science

Total Enrolled in Biol 0123	70	100.00%	49	100.00%	65	100.00%	43	100.00%	46	100.00%
A, B, or C	51	72.86%	31	63.27%	57	87.69%	34	79.07%	34	73.91%
D or F	14	20.00%	9	18.37%	4	6.15%	6	13.95%	11	23.91%
I	0	0.00%	0	0.00%	0	0.00%	0	0.00%	0	0.00%
W	5	7.14%	9	18.37%	4	6.15%	3	6.98%	1	2.17%
Continued Immediately with: (completed Biol 0123 with A, B, or C)										
Biol 1114	10	100.00%	6	100.00%	4	100.00%	0	0.00%	4	100.00%
A, B, or C	3	30.00%	4	66.67%	3	75.00%	0	0.00%	3	75.00%
D or F	1	10.00%	2	33.33%	1	25.00%	0	0.00%	1	25.00%
I	0	0.00%	0	0.00%	0	0.00%	0	0.00%	0	0.00%
W	6	60.00%	0	0.00%	0	0.00%	0	0.00%	0	0.00%
Biol 1144	11	100.00%	5	100.00%	4	100.00%	5	100.00%	6	100.00%
A, B, or C	2	18.18%	3	60.00%	1	25.00%	3	60.00%	3	50.00%
D or F	1	9.09%	1	20.00%	2	50.00%	2	40.00%	2	33.33%
I	0	0.00%	0	0.00%	0	0.00%	0	0.00%	0	0.00%
W	8	72.73%	1	20.00%	1	25.00%	0	0.00%	1	16.67%

Enrolled in: (Scored high enough on Stanford Science Test to waive zero- level)										
Biol 1114	38	100.00%	29	100.00%	45	100.00%	60	100.00%	43	100.00%
A, B, or C	22	57.89%	21	72.41%	31	68.89%	43	71.67%	25	58.14%
D or F	4	10.53%	6	20.69%	12	26.67%	9	15.00%	14	32.56%
I	0	0.00%	0	0.00%	0	0.00%	0	0.00%	0	0.00%
W	12	31.58%	2	6.90%	2	4.44%	8	13.33%	4	9.30%
Biol 1144	63	100.00%	49	100.00%	58	100.00%	53	100.00%	49	100.00%
A, B, or C	21	33.33%	23	46.94%	29	50.00%	24	45.28%	23	46.94%
D or F	16	25.40%	18	36.73%	11	18.97%	19	35.85%	14	28.57%
I	0	0.00%	0	0.00%	0	0.00%	0	0.00%	0	0.00%
W	26	41.27%	8	16.33%	18	31.03%	10	18.87%	12	24.49%

	Fall 2007		Fall 2008		Fall 2009		Fall 2010		Fall 2011	
	actual	percentage	actual	percentage	actual	percentage	actual	percentage	actual	percentage
Enrolled in: (Scored high enough on ACT to waive zero-level)										
Biol 1114	125	100.00%	122	100.00%	156	100.00%	156	100.00%	159	100.00%
A, B, or C	92	73.60%	98	80.33%	128	82.05%	127	81.41%	123	77.36%
D or F	17	13.60%	14	11.48%	16	10.26%	22	14.10%	24	15.09%
I	0	0.00%	0	0.00%	0	0.00%	0	0.00%	0	0.00%
W	16	12.80%	10	8.20%	12	7.69%	7	4.49%	12	7.55%
Biol 1144	241	100.00%	176	100.00%	200	100.00%	217	100.00%	238	100.00%
A, B, or C	110	45.64%	115	65.34%	122	61.00%	145	66.82%	167	70.17%
D or F	45	18.67%	37	21.02%	47	23.50%	39	17.97%	37	15.55%
I	0	0.00%	0	0.00%	0	0.00%	0	0.00%	0	0.00%
W	86	35.68%	24	13.64%	31	15.50%	33	15.21%	34	14.29%

Enrolled in: (Remedial cleared by other ways-transfer, previous zero-level,etc.)										
Biol 1114	39	100.00%	33	100.00%	47	100.00%	31	100.00%	30	100.00%
A, B, or C	30	76.92%	27	81.82%	35	74.47%	22	70.97%	23	76.67%
D or F	4	10.26%	5	15.15%	7	14.89%	5	16.13%	5	16.67%
I	0	0.00%	0	0.00%	0	0.00%	0	0.00%	0	0.00%
W	5	12.82%	1	3.03%	5	10.64%	4	12.90%	2	6.67%
Biol 1144	107	100.00%	70	100.00%	64	100.00%	67	100.00%	70	100.00%
A, B, or C	53	49.53%	44	62.86%	42	65.63%	46	68.66%	47	67.14%
D or F	12	11.21%	16	22.86%	15	23.44%	12	17.91%	10	14.29%
I	0	0.00%	0	0.00%	0	0.00%	0	0.00%	0	0.00%
W	42	39.25%	10	14.29%	7	10.94%	9	13.43%	13	18.57%